

**Flange type three speed circulation pump**  
**Bomba de circulación de tres velocidades tipo brida**  
**Pompe de circulation à trois vitesses à bride**  
**Трехскоростной циркуляционный насос фланцевого типа**

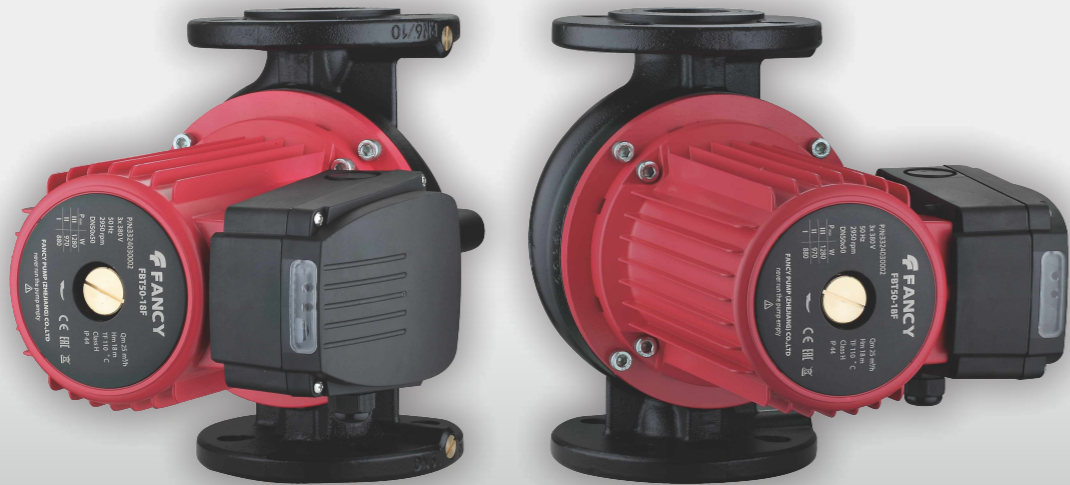

**DESCRIPTION/DESCRIPCIONES/DESCRIPTION/ОПИСАНИЕ**

- ♦ Three speed adjustment for water pressurization.
- ♦ Three/Single phase circulation pump with flange.
- ♦ Ceramic wet rotor motor, low noise.
- ♦ No mechanical seal, low failure rate.
- ♦ Pump body with anticorrosive electrophoresis.
- ♦ Easy use and installation.
- ♦ Extreme silent, maintenance-free.
- ♦ Temperature of the liquid to +110 °C.

- ♦ Ajuste de tres velocidades para la presurización del agua.
- ♦ Bomba de circulación trifásico/monofásico con brida.
- ♦ Motor de rotor húmedo de cerámica, bajo nivel de ruido.
- ♦ Sin sello mecánico, baja tasa de fallas.
- ♦ Cuerpo bomba con electroforesis anticorrosiva.
- ♦ Fácil uso e instalación.
- ♦ Extremadamente silencioso, libre de mantenimiento.
- ♦ Temperatura del líquido a +110 °C.

- ♦ Réglage à trois vitesses pour la pressurisation de l'eau.
- ♦ Pompe de circulation triphasé/monophasé avec bride.
- ♦ Moteur à rotor humide en céramique, à faible bruit.
- ♦ Pas de joint mécanique, faible taux d'échec.
- ♦ Corps de pompe avec électrophorèse anticorrosion.
- ♦ Utilisation et installation faciles.
- ♦ Extrêmement silencieux, sans entretien.
- ♦ Température du liquide à +110 °C.

- ♦ Три скорости регулировки давления воды.
- ♦ Трехфазный/Однофазный циркуляционный насос с фланцем.
- ♦ Двигатель с керамическим мокрым ротором, низкий уровень шума.
- ♦ Отсутствие механического уплотнения, низкий уровень отказов.
- ♦ Корпус насоса с антикоррозийным электрофорезом.
- ♦ Простота использования и установки.
- ♦ Чрезвычайно тихий, не требующий обслуживания.
- ♦ Температура жидкости до +110 °C.

**APPLICATIONS/APLICACIONES/APPLICATIONS/ПРИЛОЖЕНИЯ**

- ♦ For water pressure boosting in household like apartment, villa, residences, cooling or air-conditioning system internal circulation, and boiler and solar system, etc.
- ♦ Para aumentar la presión del agua en hogares como apartamentos, villas, residencias, refrigeración o aire acondicionado Sistema de circulación interna, caldera y sistema solar, etc.
- ♦ Pour augmenter la pression de l'eau dans les ménages comme appartements, les villas, les résidences, le refroidissement ou la climatisation circulation interne du système, et chaudière et système solaire, etc.
- ♦ Для повышения давления воды в домашних условиях, таких как квартира, вилла, жилой дом, охлаждение или кондиционирование воздуха. система внутренней циркуляции, бойлер и солнечная система и т. д.

**MODEL CODE/CÓDIGO MODELO/ CODE MODÈLE/ КОД МОДЕЛИ**

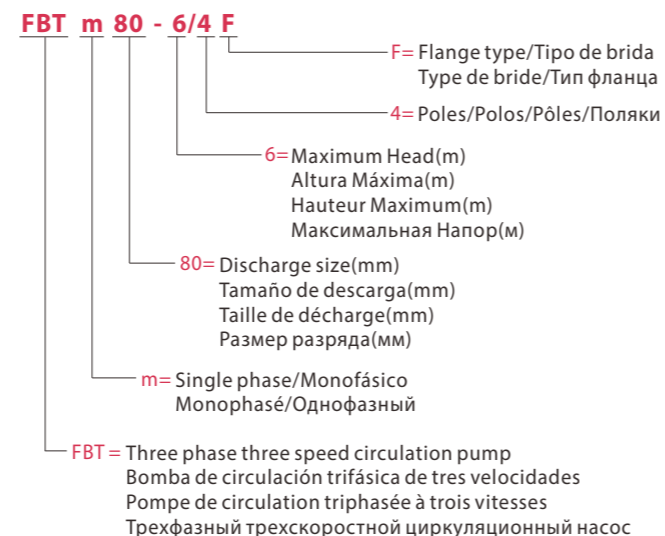

**TECHNICAL DATA/DATOS TÉCNICOS/DONNÉES TECHNIQUES/ТЕХНИЧЕСКИЕ ДАННЫЕ**

60Hz n≈3500/1750 l/min

MODEL MODELO MODÈLE МОДЕЛЬ	DN	Power Potencia Puissance Мощность	Qm	Hm	SS304	Q=Delivery/Caudal/Débit/Подача															
						GPM 0	13	26	44	53	62	70	79	88	110	154	176	198	220	233	
1-ph	3-ph	mm	W	m <sup>3</sup> /h	m	I/min 0	50	100	167	200	233	267	300	333	417	583	667	750	833	883	
						H=Head(m)/Altura(m)/Hauteur(m)/Напор (м)															
FBTm32-6F	FBT32-6F	32x32	235/170/150	10/8.5/8.1	6.5/6/5.6	SS304	6.5	5.7	4.5	2.5	-	-	-	-	-	-	-	-	-	-	-
FBTm32-9F	FBT32-9F	32x32	370/280/260	12/10.5/9.8	9.3/8.3/8	SS304	9.3	8.9	7.8	5.5	4	-	-	-	-	-	-	-	-	-	-
FBTm40-6F	FBT40-6F	40x40	260/190/175	11/9.5/9	6/5.5/5.1	SS304	6	5.5	5	3.5	2.5	-	-	-	-	-	-	-	-	-	-
FBTm40-9F	FBT40-9F	40x40	560/430/390	14/12/11.3	10/9/8.5	SS304	10	9.5	8.5	7	6	4.8	-	-	-	-	-	-	-	-	-
FBTm40-13F	FBT40-13F	40x40	750/540/480	16/13/11.6	13/10.5/9.7	SS304	13	12	11	9.5	8.3	7	5.5	-	-	-	-	-	-	-	-
FBTm40-18F	FBT40-18F	40x40	1090/710/590	16.5/13/11.5	18/13.5/11.3	SS304	18	16.3	14.5	12	10.5	9	7	-	-	-	-	-	-	-	-
FBTm50-6F	FBT50-6F	50x50	360/260/230	16/12.5/11.5	6.2/5.5/5	SS304	6.2	6	5.5	4.7	4.2	3.5	2.5	-	-	-	-	-	-	-	-
FBTm50-9F	FBT50-9F	50x50	680/500/460	20/17/15	9.5/8.5/7.5	SS304	9.5	-	9	8.3	7.7	7	6.2	5.3	4	-	-	-	-	-	-
FBTm50-13F	FBT50-13F	50x50	1160/750/620	26/19.8/17.8	12.8/10.8/9.8	SS304	12.8	-	12	11.4	11	10.5	10	9.5	9	6.8	-	-	-	-	-
FBTm50-18F	FBT50-18F	50x50	1280/970/880	25/22/21	18/16/15	SS304	18	-	17	15.5	14.5	13.8	12.7	11.5	10	6.5	-	-	-	-	-
FBTm65-6F	FBT65-6F	65x65	490/370/340	26/22/21	6.5/6/5.7	SS304	6.5	-	-	5.2	5	4.5	4.2	3.5	3.3	2.2	-	-	-	-	-
FBTm65-9F	FBT65-9F	65x65	1010/670/570	36/28/24	10.5/8.7/8	SS304	10.5	-	-	9.5	9	8.8	8.5	8.1	7.8	6.7	4.2	-	-	-	-
-	FBT65-13F	65x65	1420/1060/930	45/35/32	13.5/12.1/11.2	SS304	13.5	-	-	-	-	12.5	12.3	12	11.6	10.6	8	7	5	-	-
-	FBT65-18F	65x65	1725/1229/1059	50/36/32	18/15.2/14	SS304	18	-	-	-	-	-	15.5	15	14.8	13.5	10.5	9	7.2	6	-
FBTm80-6/4F	FBT80-6/4F	80x80	780/500/430	50/35/32	5/4.3/4	SS304	5	-	-	-	-	-	-	-	4.5	4.2	3.6	3	2.5	2	-
-	FBT80-9F	80x80	1490/1070/940	53/44/41	9.7/8/7.5	SS304	9.7	-	-	-	-	-	-	-	8	7.5	6.2	5.6	5	4	3.5

PERFORMANCE CURVE/CURVA DE RENDIMIENTO/SOURCE DE PERFORMANCE/КРИВАЯ ПРОИЗВОДИТЕЛЬНОСТИ

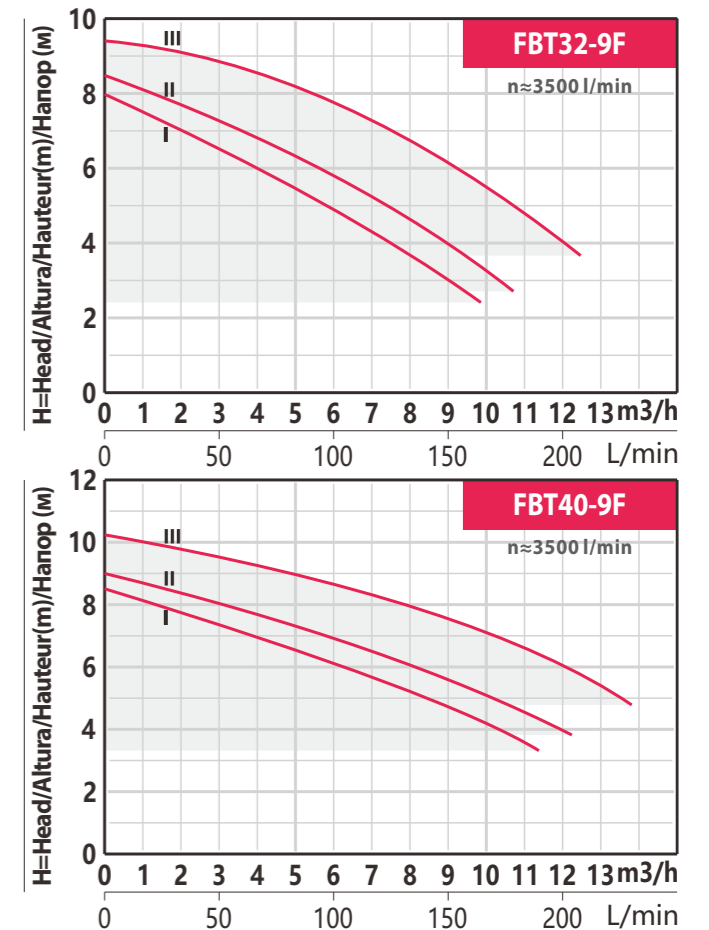
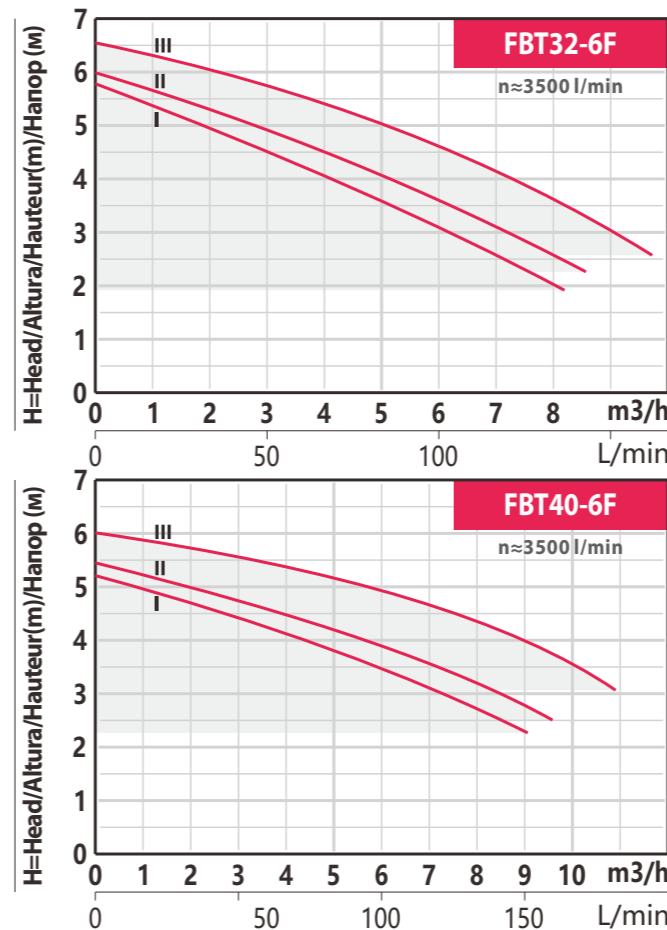

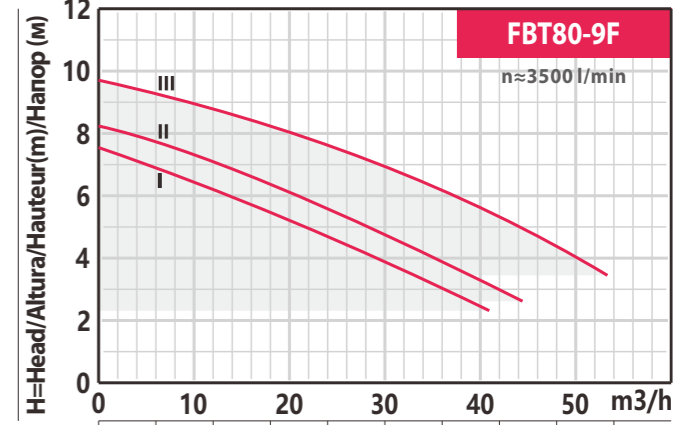
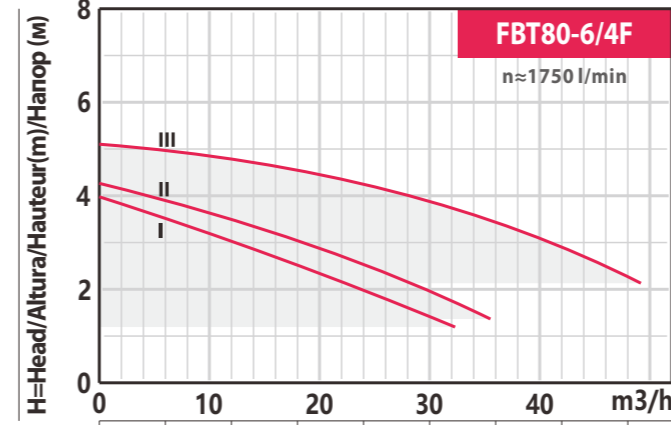
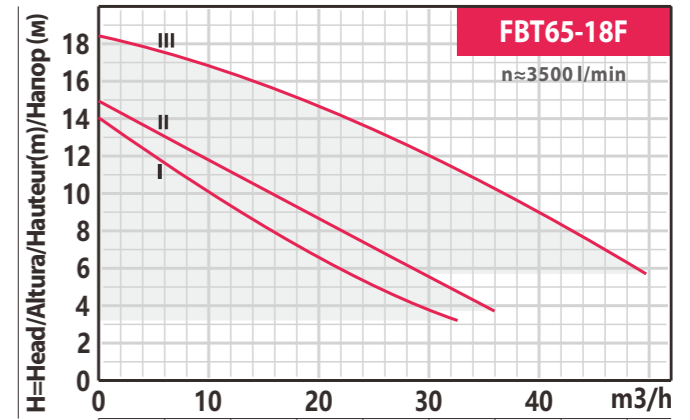
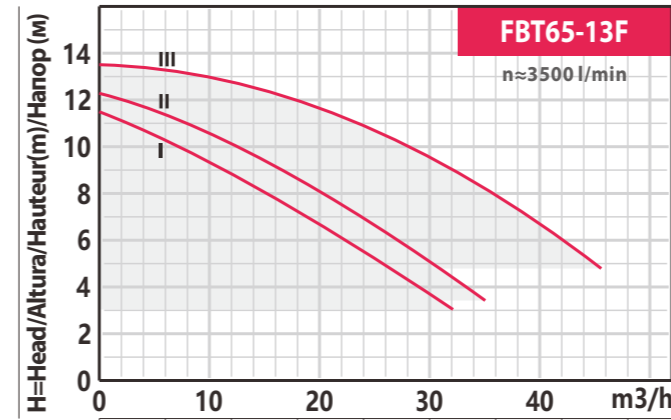
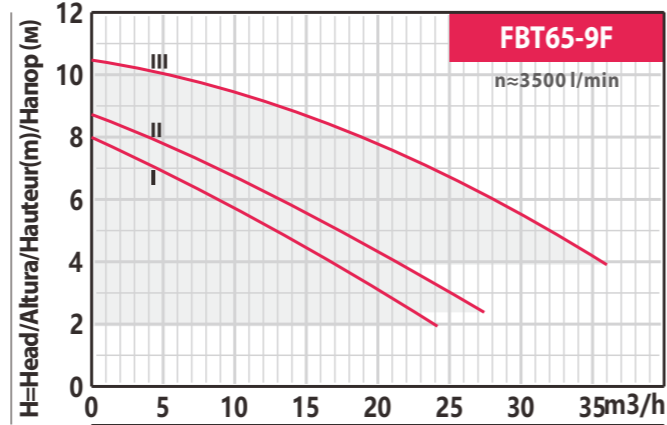
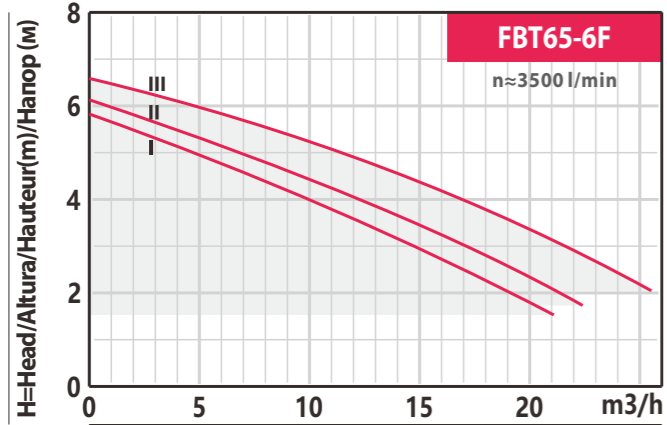
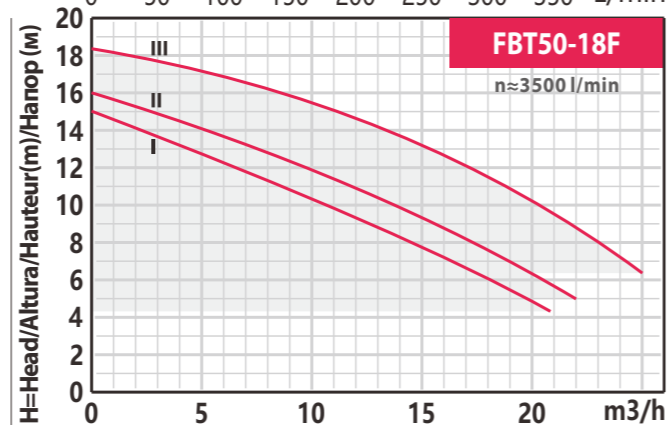
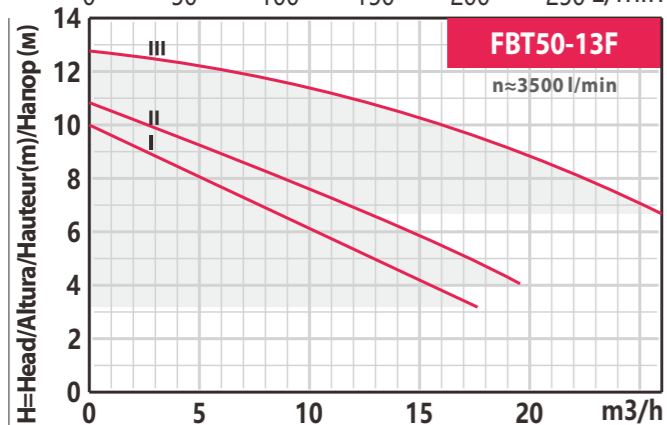
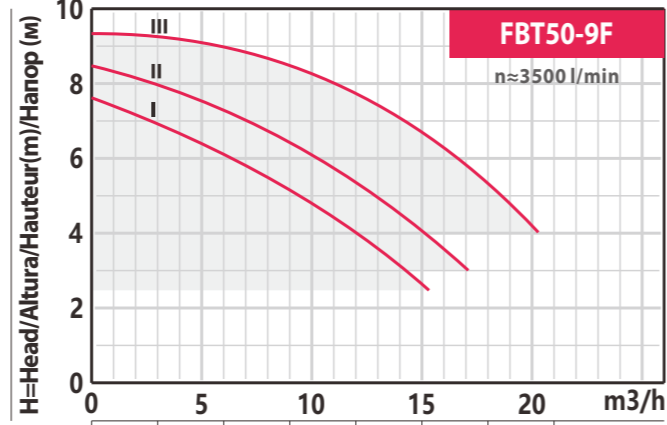
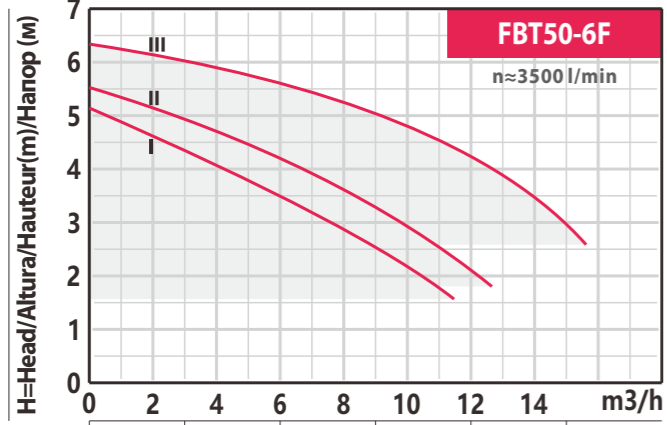
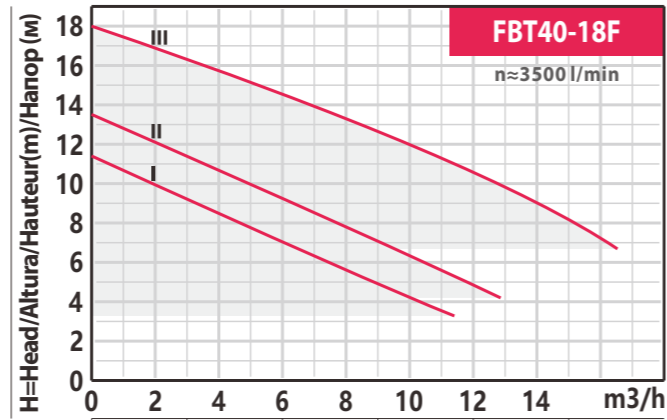
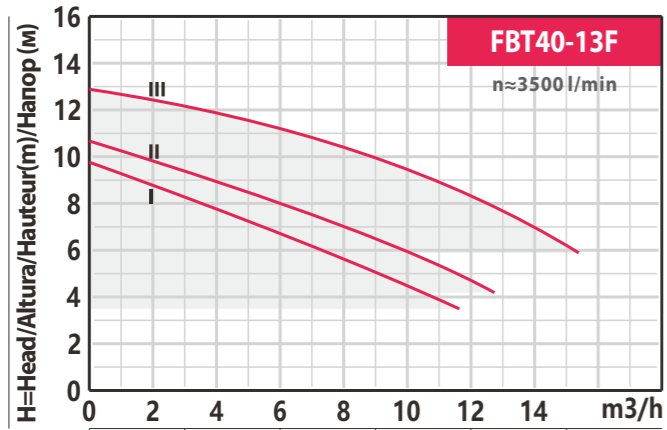

DIMENSIONS AND N.W./DIMENSIONES Y PESOS/DIMENSIONS ET POIDS/РАЗМЕРЫ И ВЕС

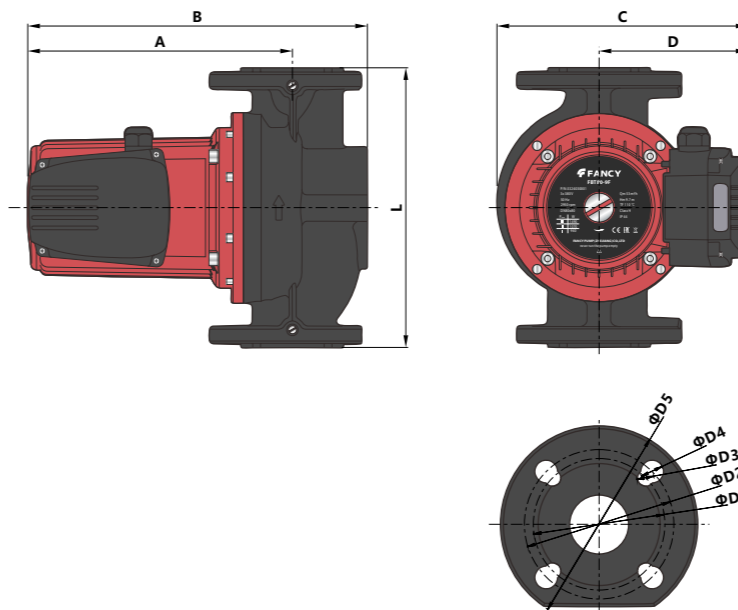

MODEL MODELO MODÈLE МОДЕЛЬ	DIMENSIONS/DIMENSIONES DIMENSIONS/РАЗМЕРЫ									GW Kg	
	L	A <sub>(1/3ph)</sub>	B <sub>(1/3ph)</sub>	C	D	D1	D2	D3	D4		D5
FBT32-6F	220	233	292	228	80	90	100	14	19	140	19.5
FBT32-9F	220	233	292	228	80	90	100	14	19	140	20
FBT40-6F	250	230	298	228	100	100	110	14	19	150	20.5
FBT40-9F	250	262/232	329/299	250	100	100	110	14	19	150	26
FBT40-13F	250	262/232	329/299	250	100	100	110	14	19	150	26
FBT40-18F	250	262	329	250	100	100	110	14	19	150	25.5
FBT50-6F	280	209	281	236	88	110	125	14	19	165	24
FBT50-9F	280	239/209	331/281	236	88	110	125	14	19	165	28
FBT50-13F	280	262	337	252	102	110	125	14	19	165	28
FBT50-18F	280	262	337	252	102	110	125	14	19	165	29
FBT65-6F	340	256/226	341/311	246	96	130	145	14	19	185	30
FBT65-9F	340	256	341	246	96	130	145	14	19	185	31
FBT65-13F	340	286	371	246	96	130	145	14	19	185	30
FBT65-18F	340	306	385	264	114	130	145	14	19	185	31
FBT80-6/4F	360	308	415	276	126	/	160	/	8*19	200	38.5
FBT80-9F	360	308	415	276	126	/	160	/	8*19	200	38.7